

Real Time Ware, Inc. Introduces

FMT3000 FERROMAGNETIC TAGGING OF CEMENT

BENEFITS

- ❖ 100%, REAL TIME INSPECTION OF RAW MIX, PRE-CLINKER MATERIAL.
- ❖ ELECTRONIC FOOTPRINT OF FINAL CEMENT.
- ❖ MONITORS PRODUCT DURING MIXING AT CONSTRUCTION SITE.
- ❖ MONITORS FINISHED PRODUCT, ROADS, BUILDINGS....
- ❖ PORTABLE EQUIPMENT FOR ON SITE TESTING.

PATENTED AND PATENTS PENDING.

100% INSPECTION

- ❑ The mixing of any two materials is monitored.
- ❑ Iron and silicon are accurately mixed and tested.
- ❑ Each additional component is verified for correct mix ratio.
- ❑ If any mixture is not on ratio FMT3000 will signal the controller.
- ❑ Continuous gathering of data.
- ❑ History of material.

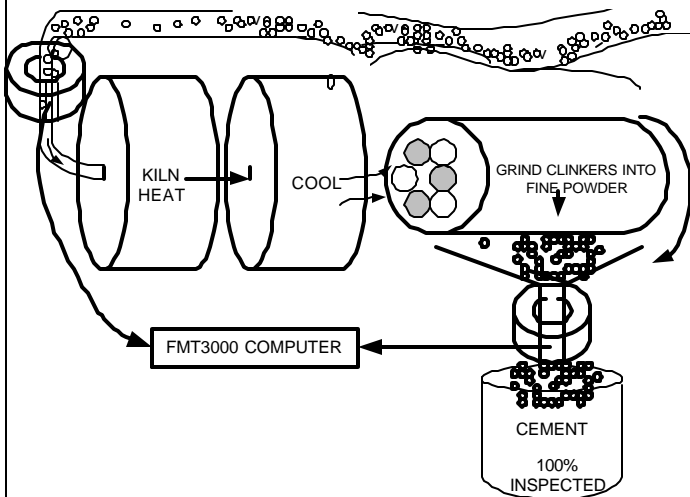
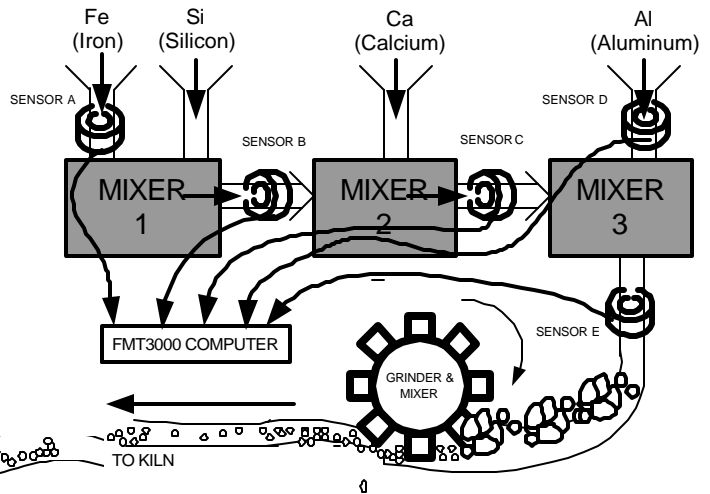

INSPECTION OF FINAL PRODUCT

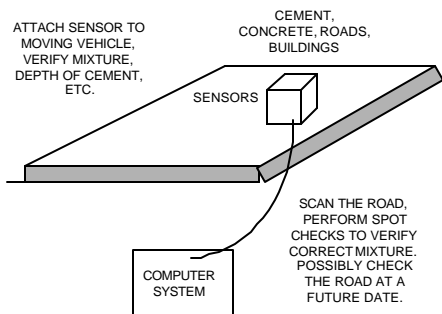

VERIFICATION OF FINAL MIXTURE

- ❑ Pre-clinker material and final cement is continuously monitored.



Real Time Ware, Inc.
NEW BALTIMORE, ...
586-725-8850

email: info@realtimewareinc.com
www.realtimewareinc.com